

VARIATIONS IN RAINWATER QUALITY FROM ROOF CATCHMENTS

M. I. YAZIZ, H. GUNTING, N. SAPARI and A. W. GHAZALI

Department of Environmental Sciences, Universiti Pertanian Malaysia, 43400, Serdang, Selangor, Malaysia

(First received July 1988; accepted in revised form January 1989)

Abstract—The quality of rainwater from a tile and a galvanized-iron type roof catchments were analysed over a period of 5 months. Examination of staggered 1 litre samples collected during a rainfall event showed that the concentration of various pollutants were high in the first litre but decreased in subsequent samples with few exceptions. Faecal coliform and total coliform counts ranged from 8–13 (tile roof) and 4–8 (iron roof) to 41–73 (tile roof) and 25–63 (iron roof) colonies per 100 ml, respectively. However, no faecal coliforms were detected in the fourth and fifth litre samples from both roofs. The pH of rainwater collected from the open was acidic but increased slightly after falling on the roofs. The average zinc concentrations in the run-off from the galvanized-iron roof was about 5-fold higher compared to the tile roof, indicating leaching action but was well below the WHO limits for drinking water quality. Lead concentrations remained consistently high in all samples collected and exceeded the WHO guidelines by a factor of 3.5. For the roof area studied, a "foul flush" volume of 51 would be the minimum to safeguard against microbiological contamination but the high metals content in the water indicate the need for some form of treatment. Rainfall intensity and the number of dry days preceding a rainfall event significantly affects the quality of run-off water from the catchment systems.

Key words—rainwater quality, water microbiology, coliforms, rainwater harvesting

INTRODUCTION

Various low-cost technologies for water supply have been developed with the aim of supplying safe and wholesome water to people in rural areas. In Malaysia, the variety of systems in use include the gravity-feed piped water system, the pumped piped water supply system, the hydraulic-ran piped water supply system, the well water supply system, the rainwater supply system and several others. Rainwater supply is considered in areas where no other suitable sources are available. Rainwater is collected from the roof run-off and stored in appropriate water tanks. If carefully collected, rainwater is relatively safe for domestic use but problems may arise if the roofs become heavily contaminated due to settlement of pollutants from the atmosphere and also from animal droppings. Hence, participants involved in rainwater harvesting schemes must be made fully aware of the health consequences of the microbiological, organic and mineral contamination in the run-off water which they are collecting and to take appropriate measures to avoid storing contaminated water in their systems.

This research addresses itself to the variations in run-off water quality from roof rainwater catchment systems. The focus is to determine the quality of the initial run-off during a rainfall event and to identify a suitable "foul flush" volume before the water is considered suitable for storage.

MATERIALS AND METHODS

Roof types and location

Two types of roof catchments were evaluated, i.e. a galvanized-iron roof and a concrete tile roof. Both catchments are sited about 1 km apart and located about 2 km away from a major public highway near the University of Agriculture campus in Serdang, Selangor. Both catchments measure approx. 5 × 3 m with no tree branches overhanging them. The galvanized-iron roof catchment (Roof 1) is located in the campus while the tile roof catchment (Roof 2) is located in a housing estate adjacent to the campus. The gutter and rainwater collection systems were constructed of polyvinylchloride (pvc) material.

Sampling systems

A staggered rainwater collection system was constructed to collect 1 litre aliquots of run-off rainwater from the roof catchments as shown in Fig. 1(a). Altogether, five 1-litre Duran bottles were linked via pvc piping to collect the rainwater samples. Each bottle also contained a ping pong ball to block the mouth of the bottle as it fills up [Fig. 1(b)] and the stem pipe was tilted 5° upwards at the upper end to help prevent water from entering the later sampling bottles during a rainfall event. All sampling bottles were sterilized by autoclaving whilst the other fittings were disinfected by immersion in boiling water for 10 min.

Rainwater was also collected from the open at a height of one metre from the ground as control. Sampling was carried out from September 1987 to January 1988. The number of dry days preceding each rainfall event was recorded together with the rainfall intensity during the first 15 min of rain. Other meteorological parameters were obtained from a recording station in the campus.

Analysis

The following parameters were analysed for each sample of rainwater collected: pH, temperature, conductivity, total solids, dissolved solids, suspended solids, turbidity, faecal coliforms, total coliforms, plate counts and lead and zinc concentrations. Bacteriological enumerations were carried out by the membrane filtration technique using Teepol broth (Sartorius) for faecal coliforms, McConkey agar No. 3 (Oxoid) for total coliforms and yeast extract agar for the plate counts. All analyses were carried out following *Standard Methods For the Examinations of Water and Wastewater* (APHA, 1980).

RESULTS AND DISCUSSIONS

Rainwater quality

The minimum, maximum and average values of the various parameters for rainwater collected from the open are shown in Table 1. Comparison with the World Health Organization (WHO) *Drinking Water Quality Guidelines* (Aron, 1984) indicate several departures, the most notable being pH and lead concentrations. The average pH of 5.9 is much lower than the range of 6.5–8.5 quoted in the WHO guidelines for drinking water quality. Only 2 samples (8.3%) collected conformed to the pH requirements for drinking water quality. The average lead concentration of 200 $\mu\text{g/l}$ is 4 times greater than the WHO

limit for drinking water quality (50 $\mu\text{g/l}$). Only 5 samples (20.8%) contained < 50 $\mu\text{g/l}$ lead. The high lead concentrations in the rainwater could most probably be attributed to a "wash-out" effect of particulate lead in the atmosphere. This is because the study sites are located in a valley with limited dispersion characteristics of atmospheric pollutants and also their close proximity to a major highway which could contribute to the particulate lead concentration in the air via motor vehicle exhaust emissions.

In general, the average values of the other parameters are in close agreement with the WHO guidelines. The dissolved solids concentrations and turbidity values were much lower than the guideline values while the bacteriological test results showed zero contamination for both, total and faecal coliforms.

Rainwater quality from roof catchments

The average values for rainwater quality obtained from the galvanized-iron (Roof 1) and concrete tile (Roof 2) roof catchments are shown in Tables 2 and 3, respectively. Except for zinc and lead concentrations, all the other parameters showed a decrease in concentration in consecutive 1-litre rainwater samples collected. The zinc concentrations in the

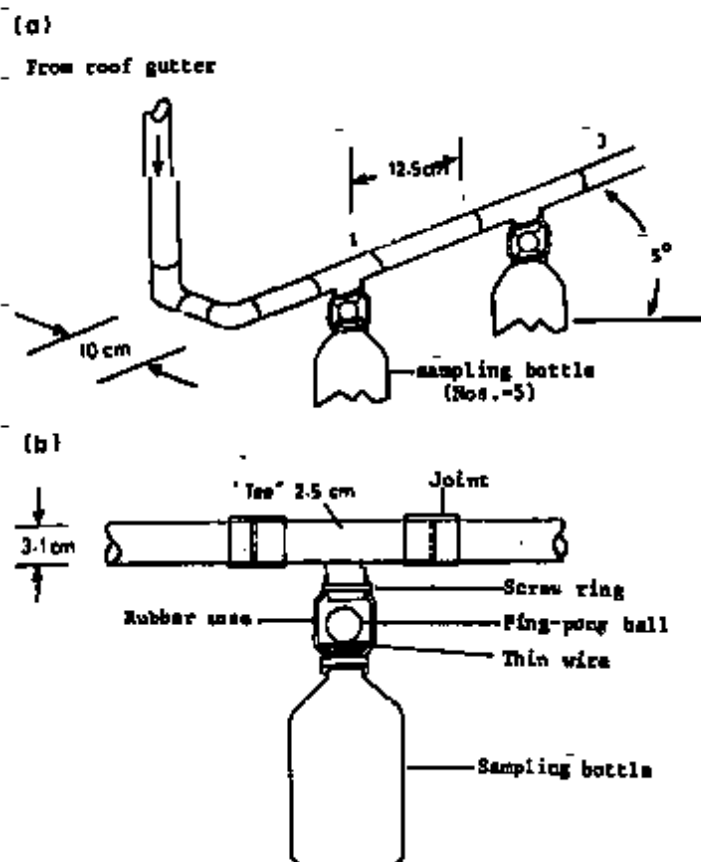

Fig. 1. (a) Run-off rainwater sampling system, (b) Sampling bottle fittings.

Table 1. Rainwater quality collected from open ground

Parameter	Unit	Minimum	Maximum	Average	n
pH		5.0	6.6	5.9	24
Temperature	°C	17.0	28.5	27.5	24
Conductivity	$\mu\text{S/cm}$	6.6	33.0	13.7	24
Turbidity	NTU	2.0	5.0	3.0	24
Total solids	mg/l	10.0	84.0	24.0	24
Suspended solids	mg/l	6.0	55.0	17.0	24
Dissolved solids	mg/l	2.0	10.0	7.0	24
Faecal col.	/100 ml	0	0	0	24
Total col.	/100 ml	0	0	0	24
Plate counts $\times 10^3$	/100 ml	5	60	34	24
Zinc	$\mu\text{g/l}$	11	80	34	24
Lead	$\mu\text{g/l}$	40	520	200	24

water collected from both roof types showed a rise up to the third litre sample but decreased sharply in the fifth litre sample. The lead concentrations in the water samples collected from Roof 2 increased sharply from the first to the third litre and then fell markedly to 169 $\mu\text{g/l}$ in the fifth litre sample. For Roof 1, the lead concentrations rose from 235 $\mu\text{g/l}$ in the first litre to 254 $\mu\text{g/l}$ in the second litre but gradually fell in the later samples to 145 $\mu\text{g/l}$. During the study period, the average rainfall intensity was 71 mm/h with an average dry period of 1.6 days between rainfall events.

In general, it is difficult to compare between roof types but an evaluation of the water quality in the fifth litre samples showed relatively better quality water from Roof 1 compared to Roof 2. However, the initial water quality was also markedly better for Roof 1. The values for turbidity, suspended solids and conductivity were appreciably much better for Roof 1 compared to Roof 2. These observations may be attributed to the nature of the roof surfaces i.e. microscopically, the "coarser" surface of the tile roof

allows for better deposition and entrapment of pollutants from the atmosphere compared to the relatively "smoother" galvanized-iron roof. Thus during a rainfall event, the amount of wash-out from Roof 2 would be greater compared to Roof 1, given similar rainfall conditions.

The average pH values increased from 5.9 for rainwater to 6.6 and 6.9 in the initial run-offs from Roofs 1 and 2, respectively. This effect may be due to the presence of basic particles which had accumulated on the roof surfaces such as organic debris, clay and mineral particles. No significant changes in temperature were observed but the run-off water samples had marginally higher temperatures due most probably to the hot roof surfaces prior to a rainfall event. The results also show that some dissolution of zinc probably occurs from Roof 1 but the concentrations in the fifth litre samples were well within the WHO limit of 5000 $\mu\text{g/l}$ for drinking water quality. The highest zinc concentration recorded in a sample was 1748 $\mu\text{g/l}$.

In general, the bacteriological quality of the water improved in subsequent samples collected from both

Table 2. Average rainwater quality from Roof type 1 (24 samples)

Parameter	Unit	S1	S2	S3	S4	S5
pH		6.6	6.6	6.6	6.5	6.4
Temperature	°C	28.1	28.1	28.0	28.0	28.0
Conductivity	$\mu\text{S/cm}$	37.0	35.3	72.1	39.3	30.7
Turbidity	NTU	22	18	15	12	10
Total solids	mg/l	119	106	94	80	64
Suspended solids	mg/l	91	81	73	63	52
Dissolved solids	mg/l	28	24	20	16	13
Faecal col.	/100 ml	4	8	4	0	0
Total col.	/100 ml	46	63	63	36	25
Plate counts $\times 10^3$	/100 ml	32	31	25	31	22
Zinc	$\mu\text{g/l}$	343	489	497	494	294
Lead	$\mu\text{g/l}$	233	254	194	166	145

Table 3. Average rainwater quality from Roof type 2 (24 samples)

Parameter	Unit	S1	S2	S3	S4	S5
pH		6.9	6.9	6.9	6.9	6.8
Temperature	°C	28.1	28.1	28.1	28.1	28.1
Conductivity	$\mu\text{S/cm}$	135.2	121.1	106.7	94.7	86.3
Turbidity	NTU	56	47	41	35	24
Total solids	mg/l	204	176	158	130	116
Suspended solids	mg/l	153	141	123	106	95
Dissolved solids	mg/l	47	39	34	27	23
Faecal col.	/100 ml	13	8	8	0	0
Total col.	/100 ml	75	46	48	44	41
Plate counts $\times 10^3$	/100 ml	51	44	46	44	41
Zinc	$\mu\text{g/l}$	48	48	193	82	96
Lead	$\mu\text{g/l}$	102	213	271	232	169

roof types. The faecal coliform counts increased in the second litre from Roof 1 but fell sharply in the third litre and was not detected in the fourth and fifth litre samples. Similarly, the total coliform counts increased and then decreased in the last two litres of water analysed but their numbers were markedly higher and were detected in all samples. For Roof 2, the bacteriological tests yielded similar results but no increases were recorded in the later samples. The plate counts showed that bacteria were always present in the air and on the roof surfaces.

Rainwater quality and dry periods between rainfall events

Table 4 shows the changes in water quality in relation to the number of dry days between rainfall events. For this purpose, the data were selected to show changes in water quality for a few chosen parameters within a range of dry day periods in between rainfall events.

In general, a positive relationship was observed between the concentration of the various pollutants in the run-off water with the dry period in-between rainfall events. This can be seen in the increase in pollutant concentrations from both roof types as the dry-period increases. For example, the turbidity values for the water from Roof 1 increased from 16 to 27 µg/l when the dry period increased and reached more than 2-fold when the dry period in-between rainfall events became longer. Similarly, the plate counts from both roof types showed more intense contamination as the dry period became longer.

Table 4. The effect of dry periods on changes in rainwater quality

Roof type	Range of dry period (days)	S1	S2	S3	S4	S5	C
<i>(a) Turbidity (NTU)</i>							
1	0.5-1.5	16	13	10	9	7	3
	1.6-2.5	27	22	18	15	12	4
	2.6-4.5	33	39	20	18	16	4
2	0.5-1.5	37	31	27	22	15	3
	1.6-2.5	65	55	46	37	27	4
	2.6-4.5	13	94	88	74	51	4
<i>(b) Total solids (µg/l)</i>							
1	0.5-1.5	103	90	79	68	53	20
	1.6-2.5	121	118	102	67	72	28
	2.6-4.5	150	140	134	113	91	29
2	0.5-1.5	169	139	121	102	94	20
	1.6-2.5	233	210	190	162	140	28
	2.6-4.5	276	249	230	188	144	29
<i>(c) Plate counts (No. × 10³/100ml)</i>							
1	0.5-1.5	22	25	20	21	20	19
	1.6-2.5	34	32	27	18	18	17
	2.6-4.5	65	52	45	30	42	22
2	0.5-1.5	38	32	36	31	25	19
	1.6-2.5	42	38	30	26	26	17
	2.6-4.5	143	129	145	149	149	22
<i>(d) Zinc (µg/l)</i>							
1	0.5-1.5	122	318	330	277	299	26
	1.6-2.5	501	618	748	534	361	39
	2.6-4.5	863	889	572	1527	367	54
2	0.5-1.5	28	35	182	37	113	26
	1.6-2.5	60	45	41	51	56	39
	2.6-4.5	112	107	647	362	135	54

Variations in rainwater quality against rainfall intensity

The data in Table 5 show the effect of rainfall intensity on the quality of rainwater from roof catchments having similar dry periods in between rainfall

Table 5. Effect of rainfall intensity on rainwater quality

Roof type	Dry period	Rainfall intensity (mm/h)	Samples					
			S1	S2	S3	S4	S5	C
<i>(a) Total solids (µg/l)</i>								
1	0.8	152	112	89	71	67	39	21
	0.8	12	97	96	81	80	63	12
	0.8	8	91	89	88	72	64	12
2	0.8	132	151	104	83	81	79	21
	0.8	12	174	161	149	121	103	11
	0.8	8	169	164	154	131	120	12
<i>(b) Turbidity (NTU)</i>								
1	0.8	152	14	11	10	6		
	0.8	12	19	18	15	13	11	3
	0.8	8	17	18	16	14	9	3
2	0.8	132	31	29	18	13	7	3
	0.8	12	31	30	29	24	23	2
	0.8	8	28	25	21	18	13	
<i>(c) Plate counts (No. × 10³/100ml)</i>								
1	0.8	152	20	13	10	8	6	6
	0.8	12	21	20	18	19	18	31
	0.8	8	20	19	18	24	25	27
2	0.8	132	16	9	8	11	13	6
	0.8	12	38	39	35	34	37	31
	0.8	8	29	28	30	31	28	27
<i>(d) Zinc (µg/l)</i>								
1	0.8	152	230	936	335	207	216	15
	0.8	12	38	80	51	48	5	18
	0.8	8	150	230	425	207	140	53
2	0.8	132	38	25	16	20	13	15
	0.8	12	10	25	26	48	500	18
	0.8	8	15	25	20	20	13	53

events. Rainfall intensity plays a major role in the "cleaning" process of a roof catchment. Under normal circumstances, the greater the rainfall intensity, the more efficient is the cleaning process due to the greater energy present in the raindrops on its impact with the roof surface. This will lead to greater and faster dislocation of pollutants trapped on the roof surface into the run-off water.

In examining the data, no firm conclusions could be made if the concentration of each pollutant was compared in relation to the rainfall intensity. This is because it is difficult to assume a uniform distribution of dust in the air during the sampling period and even more difficult to assume that it will settle evenly on the roof surfaces without supporting data. Thus the effect of rainfall intensity will be examined by its effect on water quality. For total solids, it can be seen that the reduction in concentration from the first litre to the fifth litre became more pronounced as the rainfall intensity increased from 8 to 152 mm/h for both, Roofs 1 and 2. Similar changes were also observed for the plate count results but is more difficult to explain since the combined wash-out counts are lower for the higher intensity period. Nonetheless, the "cleaning" effect appears to be more efficient on the galvanized-iron roof than the tile roof.

CONCLUSIONS

The deposition of various pollutants from the atmosphere onto roof surfaces during a dry period greatly influences the run-off water quality from a roof catchment systems. The longer the dry period in between rainfall events, the greater is the amount of pollutants deposited on the roof surfaces as shown by the increase in pollutant concentrations in the water samples taken from Roof types 1 and 2 in this study. Rainfall intensity also affects the quality of the

run-off, i.e. the wash-out process occurs faster for a particular roof surface with increases in the rainfall intensity. This reduces the foul flush volume and water may be stored after a shorter "cleansing period". Similar results were obtained by Wheeler and Lloyd (1983). Although the microbiological quality analysis showed that no faecal coliforms were detectable after the fifth litre (i.e. a minimum foul flush volume of 5 l. is necessary) the presence of high levels of total coliforms and plate counts suggests that caution is needed in selecting a suitable foul flush volume before capturing the run-off water for storage. Due to the variability in counts, further studies are needed on a longer time interval taking into account the level of microbiological contamination against duration of rainfall and the effects of rainfall intensity. The low pH of the rainwater even after falling over the roofs show that the pH values often be below the requirements of the WHO guidelines on drinking water quality. In addition, the acid rain appears to have caused some leaching of zinc from the galvanized-iron roof. The high lead concentrations in the water is alarming since it was nearly 4 times higher than the WHO guideline values. All this suggests that some form of treatment of the rainwater harvested from these locations is necessary before it can be used as a source of potable water.

REFERENCES

- ANON (1984) *Guidelines For Drinking Water Quality, Volume 1. Recommendations*. World Health Organization, Geneva.
- APHA (1980) *Standard Methods for the Examination of Water and Wastewater*, 15th edition. American Public Health Association, New York.
- Wheeler D. and Lloyd B. J. (1983) An investigation of some microbiological and physico-chemical aspects of rainwater harvesting. A report commissioned by the Intermediate Technology Development Group, University of Surrey, England.